



CAMPO DE PRESTACIONES

- Caudal hasta **160 l/min** (9.6 m³/h)
- Altura manométrica hasta **57 m**

LIMITES DE UTILIZO

- Altura de aspiración manométrica hasta **7 m**
- Temperatura del líquido de **-10 °C** hasta **+90 °C**
- Temperatura ambiente hasta **+40 °C**
- Presión máx. en el cuerpo de la bomba:
 - **6 bar** para CP 600-610-620
 - **10 bar** para CP 650-660-670-650M-660M-670M
- Funcionamiento continuo **S1**

EJECUCION Y NORMAS DE SEGURIDAD

EN 60335-1
IEC 60335-1
CEI 61-150

EN 60034-1
IEC 60034-1
CEI 2-3



CERTIFICACIONES

COMPANY WITH MANAGEMENT SYSTEM
CERTIFIED BY DNV
ISO 9001: QUALITY
ISO 14001: ENVIRONMENT AND SAFETY

UTILIZOS E INSTALACIONES

Son recomendadas para bombear agua limpia, sin partículas abrasivas y líquidos químicamente no agresivos con los materiales que constituyen la bomba.

Por su confiabilidad y simplicidad encuentran un amplio utilizzo en el sector doméstico y civil, particularmente para la distribución del agua acopladas a pequeños o medianos tanques autoclaves, para el vaciado o para la irrigación de huertos o jardines.

La instalación se debe realizar en lugares cerrados o protegidos de la intemperie.

PATENTES - MARCAS - MODELOS

- Modelo comunitario registrado n° 002098434

EJECUCION BAJO PEDIDO

- Electrobomba con rodete en tecnopolímero (CP600X, CP610X, CP620X)
- Sello mecánico especial
- Otros voltajes
- Protección IP X5 para CP 650-660-670-650M-660M-670M

GARANTIA

2 años según nuestras condiciones generales de venta

CURVAS Y DATOS DE PRESTACIONES

60 Hz n= 3450 1/min HS= 0 m

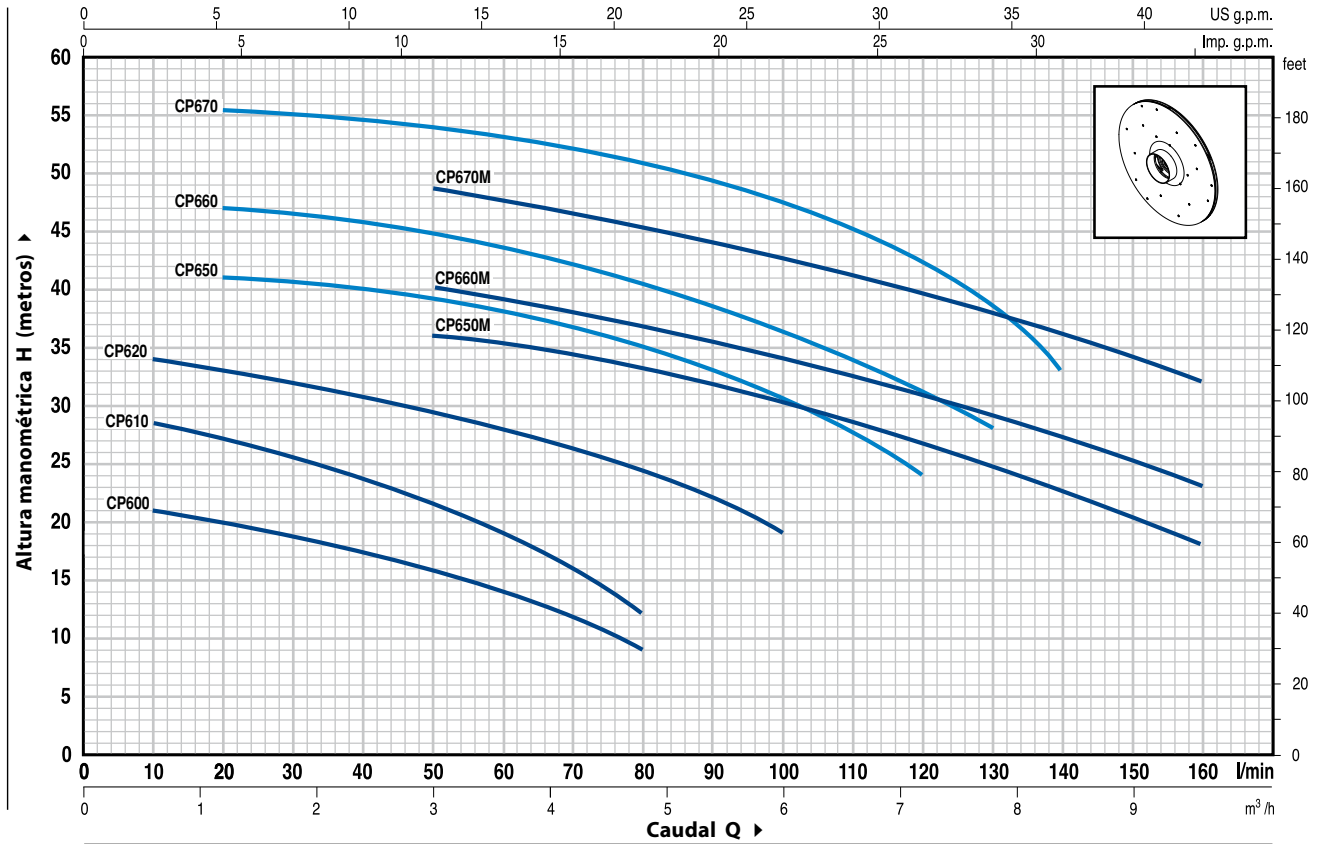

MODELO		POTENCIA		Q	H metros																		
Monofásica	Trifásica	kW	HP		m³/h	0	0.6	1.2	1.8	2.4	3.0	3.6	4.2	4.8	5.4	6.0	6.6	7.2	7.8	8.4	9.0	9.6	
				l/min	0	10	20	30	40	50	60	70	80	90	100	110	120	130	140	150	160		
CPm 600	CP 600	0.37	0.50		22	21	20	18.5	17	15.5	14	12	9										
CPm 610	CP 610	0.60	0.85		30	28.5	27	25.5	23.5	21.5	19	16	12										
CPm 620	CP 620	0.75	1		35	34	33	31.5	30.5	29.5	28	26.5	24.5	22	19								
CPm 650	CP 650	1.1	1.5		42	41.5	41	40.5	39.5	39	38	36.5	35	33	30	27	24						
CPm 660	CP 660	1.5	2		48	47.5	47	46.5	46	45	43.5	42	40.5	38.5	36	33.5	31	28					
CPm 670	CP 670	2.2	3		57	56.5	55.5	55	54	53.5	53	52	50.5	49.5	47	45	42.5	38	33				
CPm 650M	CP 650M	1.1	1.5		39	38.5	38	37	36.5	36	35	34	33	32	30	28.5	26.5	24.5	22.5	20	18		
CPm 660M	CP 660M	1.5	2		43	42.5	42	41	40.5	40	39	37.5	36.5	35	34	32.5	31	29	27	25	23		
CPm 670M	CP 670M	2.2	3		51	50.5	50.5	50	49.5	48.5	47.5	46.5	45	44	42.5	41	39.5	37.5	36	34	32		

Q = Caudal H = Altura manométrica total HS = Altura de aspiración

Tolerancia de las curvas de prestación según EN ISO 9906 Grade 3.

POS.	COMPONENTE	CARACTERISTICAS CONSTRUCTIVAS					
1	CUERPO BOMBA	Hierro fundido, con bocas roscadas ISO 228/1					
2	TAPA	Acero inoxidable AISI 304 (en hierro para CP 650-660-670-650M-660M-670M)					
3	RODETE	Acero inoxidable AISI 304					
4	EJE MOTOR	Acero inoxidable EN 10088-3 - 1.4104					
5	SELLO MECANICO	<i>Electrobomba</i>	<i>Sello</i>	<i>Eje</i>	<i>Materiales</i>		
		<i>Modelo</i>	<i>Modelo</i>	<i>Diámetro</i>	<i>Anillo fijo</i>	<i>Anillo móvil</i>	<i>Elastómero</i>
		CP 600-610	AR-12	Ø 12 mm	Cerámica	Grafito	NBR
		CP 620	AR-14	Ø 14 mm	Cerámica	Grafito	NBR
		CP 650-660-670 CP 650M-660M-670M	FN-18	Ø 18 mm	Grafito	Cerámica	NBR
6	RODAMIENTOS	<i>Electrobomba</i>	<i>Modelo</i>				
		CP 600-610	6201 ZZ / 6201 ZZ				
		CP 620	6203 ZZ / 6203 ZZ				
		CP 650-660-670 CP 650M-660M-670M	6204 ZZ / 6204 ZZ				
		7	CONDENSADOR	<i>Electrobomba</i>	<i>Capacidad</i>		
<i>Monofásica</i>	(220 V)			(110 V o 115 V o 127 V)			
CPm 600	10 µF 450 VL			25 µF 250 VL			
CPm 610	14 µF 450 VL			25 µF 250 VL			
CPm 620	20 µF 450 VL			60 µF 300 VL			
CPm 650-650M	25 µF 450 VL			60 µF 250 VL			
CPm 660-660M	31.5 µF 450 VL			60 µF 250 VL			
CPm 670-670M	50 µF 450 VL			80 µF 250 VL			
8	MOTOR ELECTRICO	<p>CPm: monofásica 220 V - 60 Hz con protección térmica incorporada en el bobinado.</p> <p>CP: trifásica 220/380 V - 60 Hz o 220/440 V - 60 Hz.</p> <p>⇒ Las bombas con motores trifásicos son de alto rendimiento en clase IE2 (IEC 60034-30)</p> <ul style="list-style-type: none"> - Aislamiento: clase F. - Protección: IP X4. 					

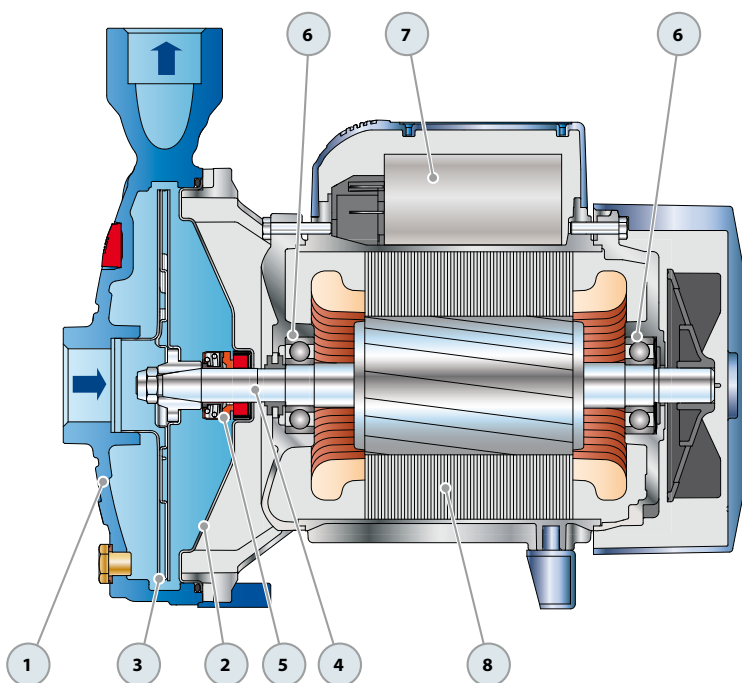

DIMENSIONES Y PESOS

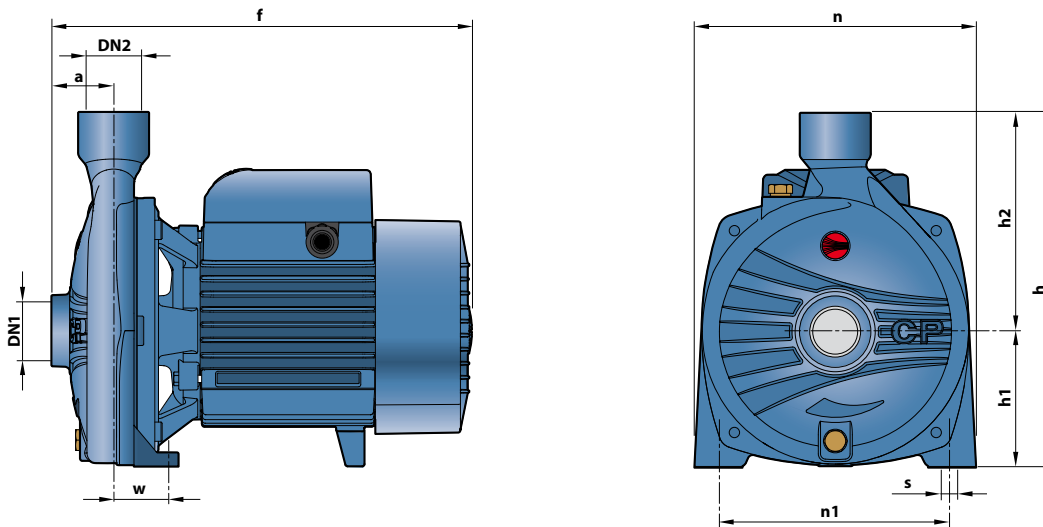

MODELO		BOCAS		DIMENSIONES mm									kg	
Monofásica	Trifásica	DN1	DN2	a	f	h	h1	h2	n	n1	w	s	1~	3~
CPm 600	CP 600	1"	1"	42	253	205	82	123	165	135	41	10	6.9	7.1
CPm 610	CP 610												8.3	8.0
CPm 620	CP 620												11.5	10.5
CPm 650 - 650M	CP 650 - 650M	1 1/4"	1"	51	367	260	110	150	206	165	44.5	11	17.8	17.2
CPm 660 - 660M	CP 660 - 660M												18.9	17.9
CPm 670 - 670M	CP 670 - 670M												20.7	20.1

CONSUMO EN AMPERIOS

MODELO	TENSION (monofásica)		
Monofásica	220 V	110 V	127 V
CPm 600	2.7 A	5.5 A	5.2 A
CPm 610	4.0 A	8.0 A	7.6 A
CPm 620	6.0 A	12.0 A	11.5 A
CPm 650 - 650M	8.8 A	17.6 A	16.7 A
CPm 660 - 660M	9.7 A	19.4 A	18.4 A
CPm 670	13.2 A	26.4 A	25.0 A
CPm 670M	12.0 A	24.0 A	22.8 A

MODELO	TENSION (trifásica)				
Trifásica	220 V	380 V	660 V	220 V	440 V
CP 600	1.8 A	1.0 A	0.6 A	2.0 A	1.2 A
CP 610	2.8 A	1.6 A	0.9 A	2.6 A	1.5 A
CP 620	4.2 A	2.4 A	1.4 A	4.4 A	2.5 A
CP 650 - 650M	5.3 A	3.1 A	1.8 A	5.6 A	3.1 A
CP 660 - 660M	6.7 A	3.9 A	2.3 A	6.4 A	4.1 A
CP 670	10.4 A	6.0 A	3.5 A	9.7 A	5.2 A
CP 670M	9.0 A	5.2 A	3.0 A	8.8 A	5.0 A

PALETIZADO

MODELO		PARA GRUPAJE				PARA CONTAINER			
Monofásica	Trifásica	n° bombas	H (mm)	1~ kg	3~ kg	n° bombas	H (mm)	1~ kg	3~ kg
CPm 600	CP 600	105	1280	742	763	189	2190	1321	1359
CPm 610	CP 610	105	1265	889	857	189	2165	1586	1529
CPm 620	CP 620	70	1440	822	752	112	2220	1305	1193
CPm 650 - 650M	CP 650 - 650M	50	1550	907	877	70	2114	1263	1221
CPm 660 - 660M	CP 660 - 660M	50	1550	962	912	70	2114	1340	1270
CPm 670 - 670 M	CP 670 - 670 M	50	1550	1052	1022	70	2114	1466	1424

